

Lube oil mist filter replacement	Respons. dept OEMS1	Date 2015-10-05	Reg. DC 105
	Prepared Dennis Jaktlund		SGT 800 B-pack

Figure 6

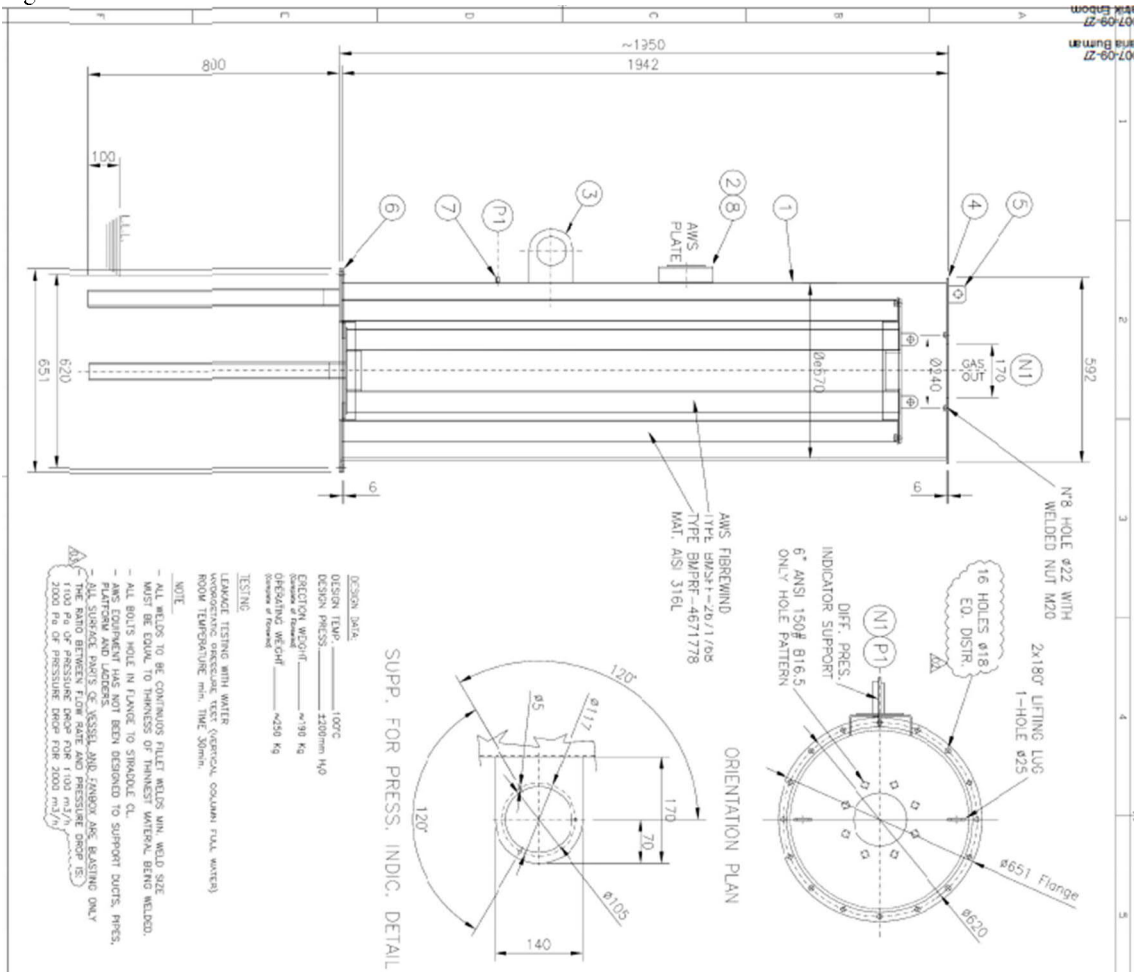

DESIGN DATA	DESIGN TIME	100%
DESIGN WEIGHT	1200mm H ₂ O	
DESIGN WEIGHT	498 kg	
OPERATING WEIGHT	428 kg	
OPERATING WEIGHT	428 kg	

TESTING

LEAKAGE TESTING WITH WATER

HYDROSTATIC PRESSURE TEST (VESSEL, COLUMN FULL WATER)

ROOM TEMPERATURE min. THE 30min.

NOTE

- ALL WELDS TO BE CONTAINER PLATE AND WELD SIZE MUST BE EQUAL TO THICKNESS OF THINNEST MATERIAL BEING WELDED.
- ALL BOLTS WELD IN FLANGE TO SIMILAR CL.
- AMS EQUIPMENT HAS NOT BEEN DESIGNED TO SUPPORT SHOTS, PRES. PLATE AND LADDERS.
- ALL SURFACE PARTS OF VESSEL AND ZANBOU ARE BLASTING ONLY.
- THE VESSEL IS TO BE PRESSURED TO 2000 PSI (138 BAR) FOR 15 MIN.
- THE VESSEL IS TO BE PRESSURED TO 2000 PSI (138 BAR) FOR 15 MIN.

This document is issued in Pulse.

We reserve all rights in this document and in the information contained therein. Reproduction, use or disclosure to third Parties without express authority is strictly forbidden.

© Siemens Industrial Turbomachinery AB

GS/AS with the same Doc.no yes <input type="checkbox"/>	Latest revision B) DJ/OEMS1/2015-12-28.	Archive	HG/UPS 4691
Approved 2015-10-05 Beatrice Antell		No. 1CS162163	
Checked 2015-10-05 Roger Jonsson			